

The Experiment of kHz laser Ranging with Nanosecond Pulses at Shanghai

Zhang Zhongping, Yang Fumin, Chen Juping,
Zhang Haifeng, Wu Zhibo, Qin Si, Li Pu

Shanghai Observatory, Chinese Academy of Sciences
Shanghai, China

Introduction

1. The aim of the experiment is to test our design of kHz control system:
 - Range Gate Generator board
 - Event Timer
 - Control software and data acquisition
 - Data processing capability
2. We are pleased to get the support from national natural science foundation in China to research on kHz SLR.
3. We borrowed a kHz laser with long pulse width from North China Research Institute of Electro-Optics.
4. On Apr.26 2008, we successfully got returns from Ajisai satellite first time with kHz system. So far, the experiment has been done at ERS-2, Lageos etc. with 2mJ energy, 50ns pulse width laser.

The kHz Laser: Main Specs

Laser

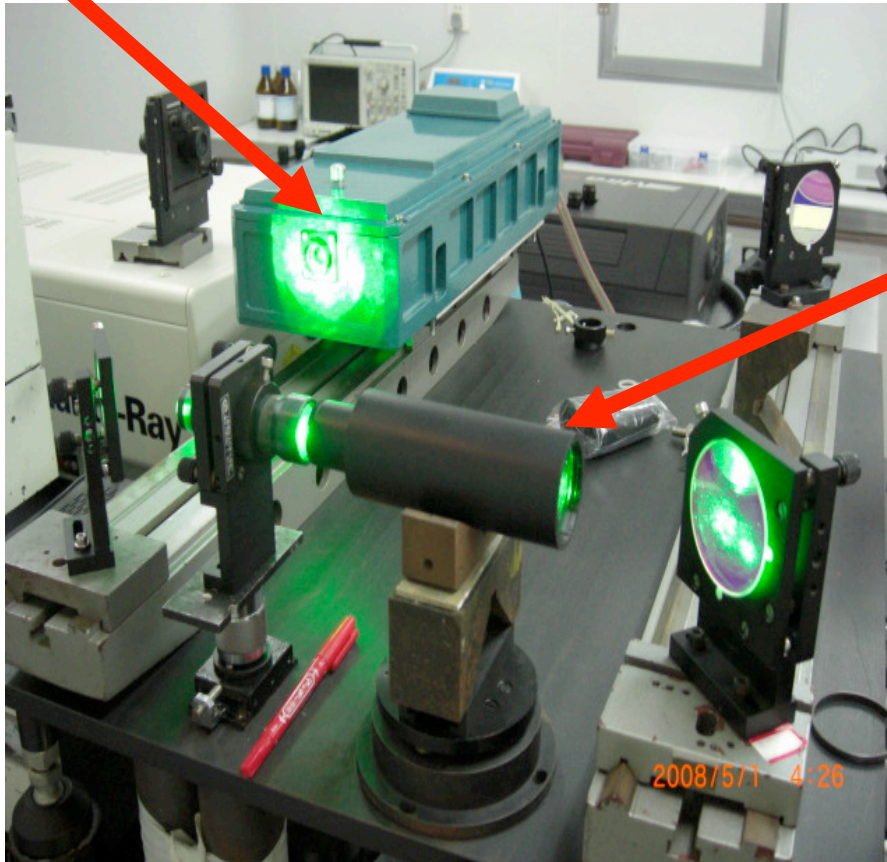

Beam
Expander

- Repetition: 1KHz (1-10kHz)
- Pulse width: 50ns
- Energy per pulse: 2mJ
- Divergence: 6mrad
- Diode pumped oscillator
- Size: 52*17*12cm**3

Made by North China Research
Institute of Electro-Optics

Control/driver



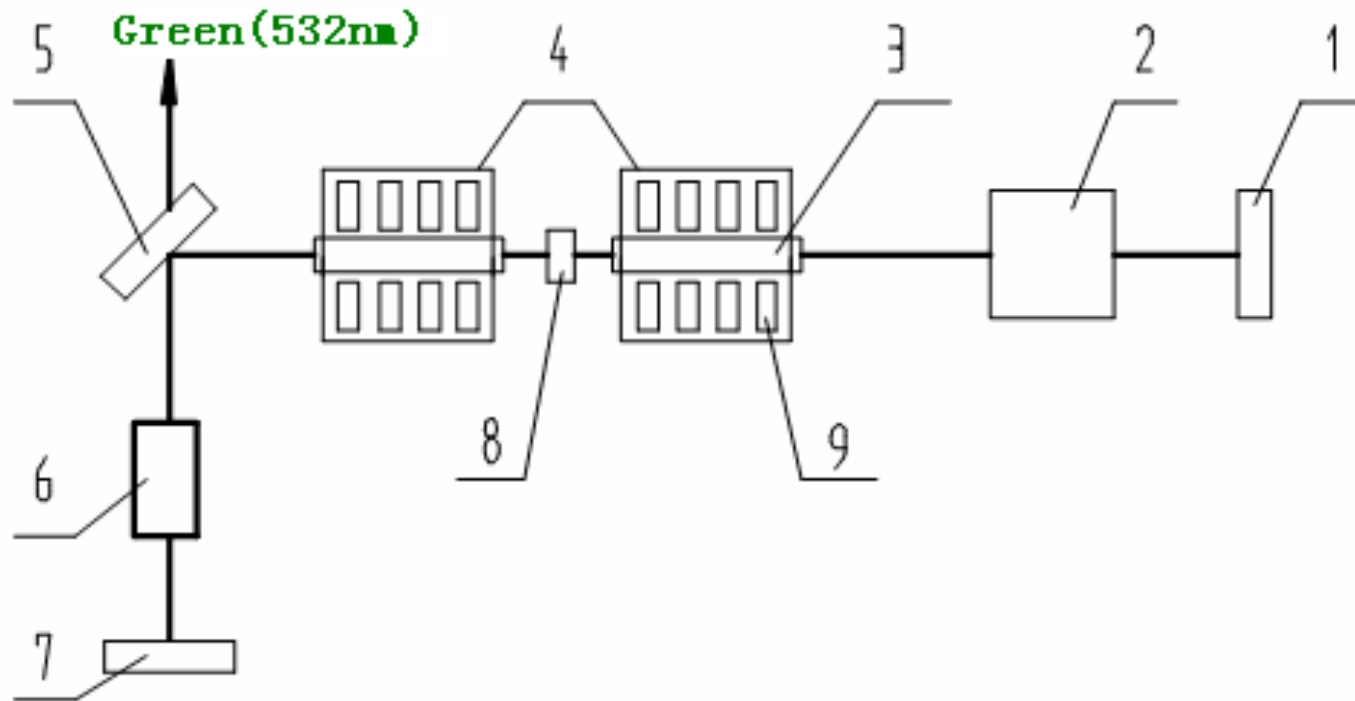

1、7 HR concave mirror; 2 acousto-optic device; 3 Nd:YAG rod;
 4 focus lamp cavity; 5 output coupling mirror; 6 SHG; 8 polarimeter;
 9 diode array

The sketch map of laser inner optical structure

A032-Event Timer

- Single shot RMS: 10ps
- FIFO: 12000 time-tags
- Measurement rate: up to 10KHz
- Communication port: EPP mode



Made by Riga, Latvia

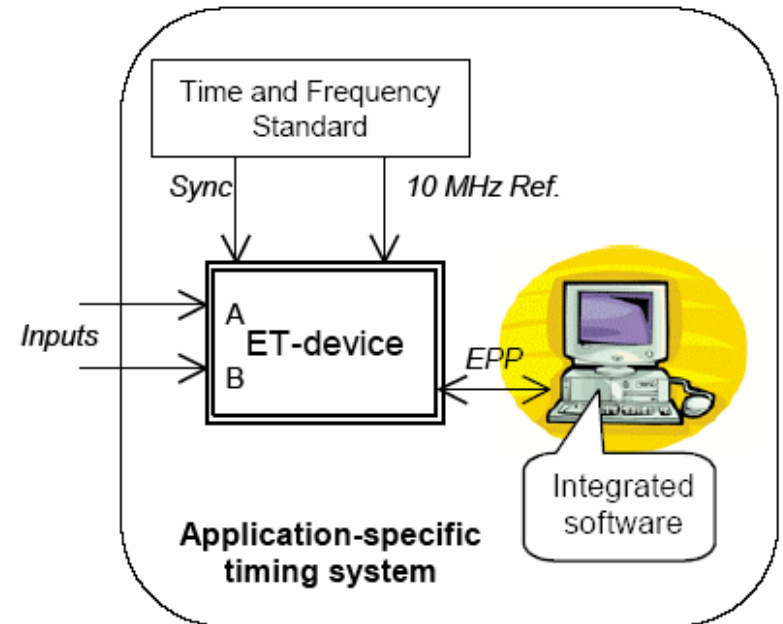

A032-Event Timer EPP mode

We exploit the Event Timer functions to adapt for KHz ranging and develop our own data acquisition software with Visual C++, according to the sample program which defines device-specific software.

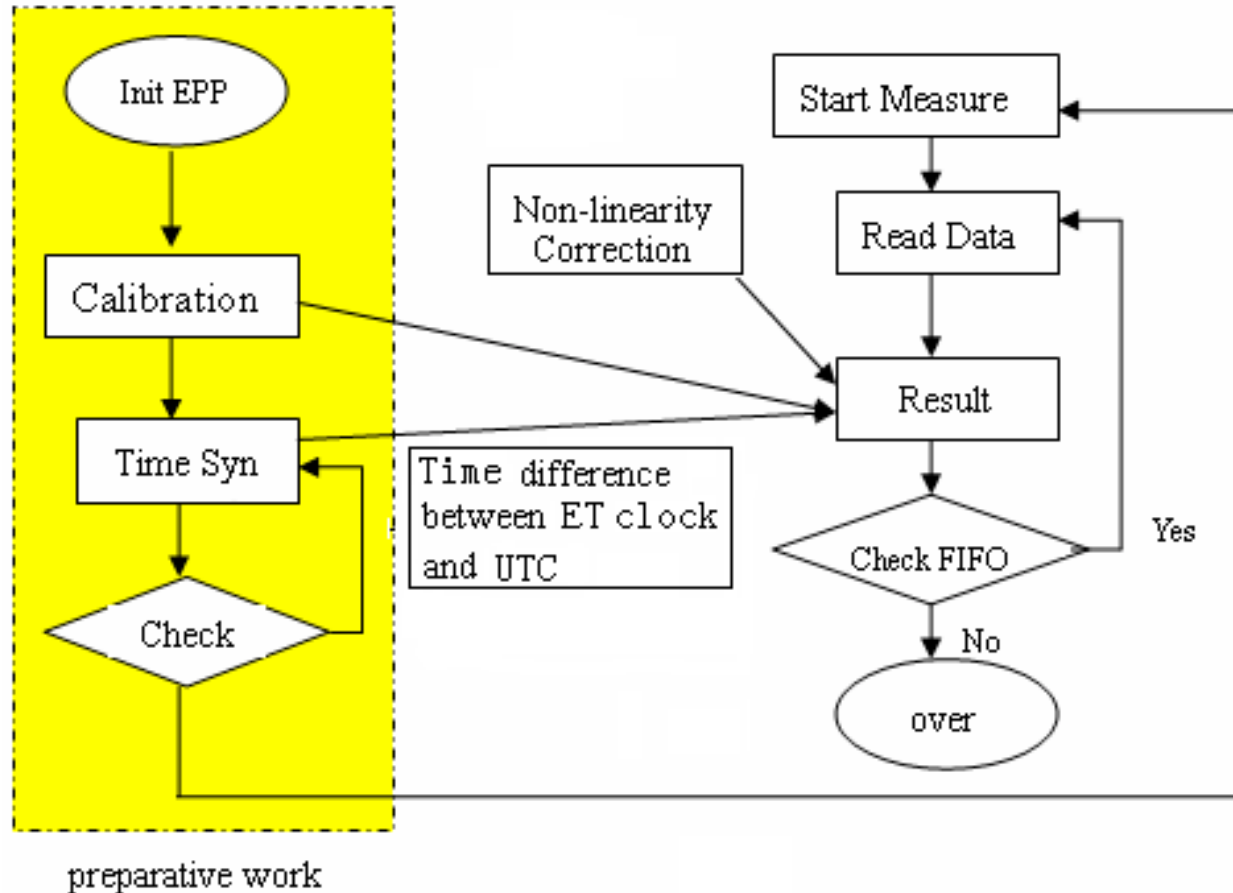

The schematic control diagram for A032-Event Timer

The kHz Range Gate Generators

- **We use two RGGs: one from Graz, another made by our group.**
- **Graz RGG board: 0.5ns resolution, 1ns accuracy, 512 buffer, ISA mode**
- **Shanghai RGG board: 5ns resolution. 1024 buffer, EPP mode**

At the begin of the experiment, Graz board is used. After that, we use our board to measure satellites.

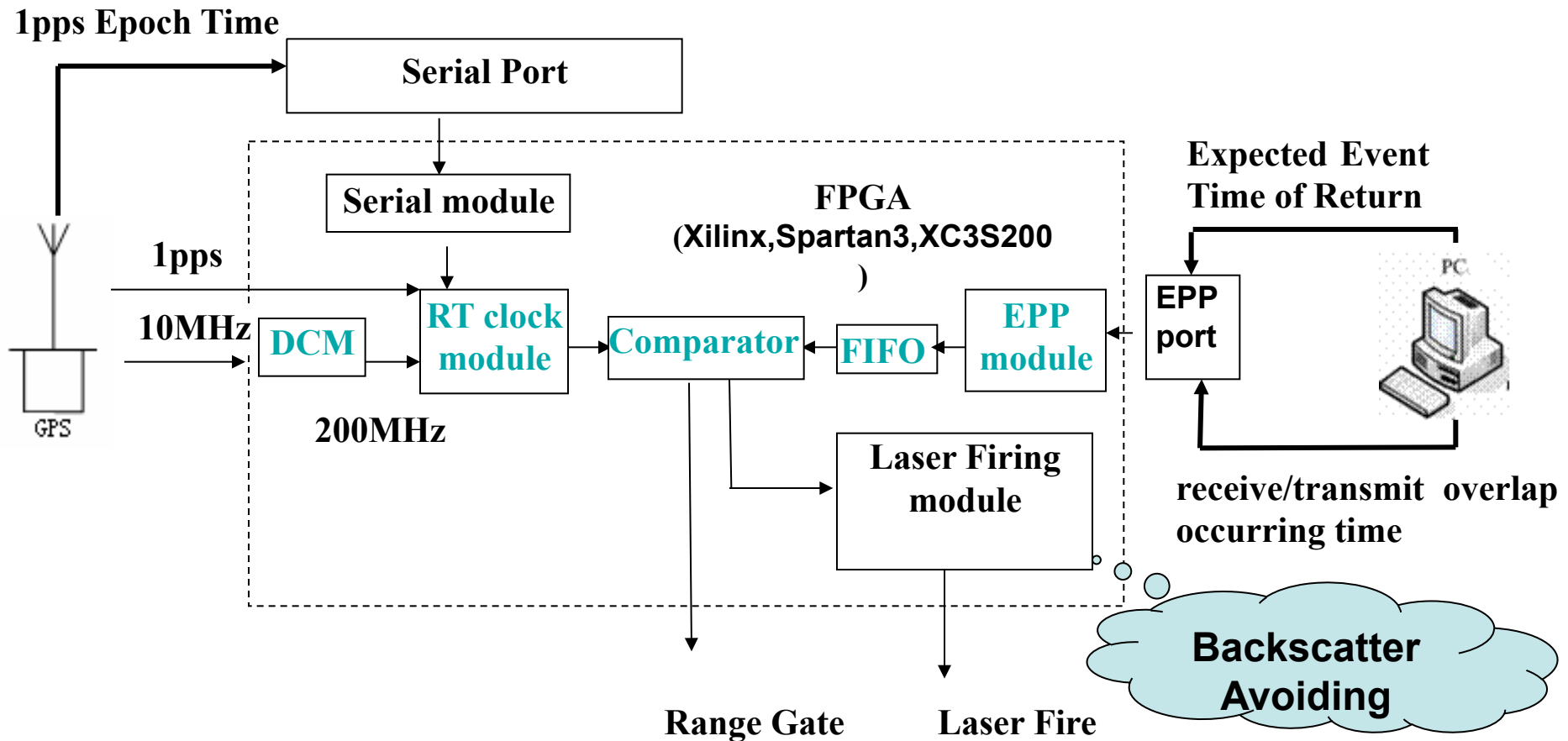

Layout of Shanghai Range Gate Generator

- **Real Time clock module sync to UTC with 5ns resolution.**
- **If Expected Event Time of Return equals to Real Time, then range gate is generated**
- **If receive/transmit overlap occurring time equals to Real Time, then backscatter avoiding function of laser firing module is start.**

Method of backscatter avoiding

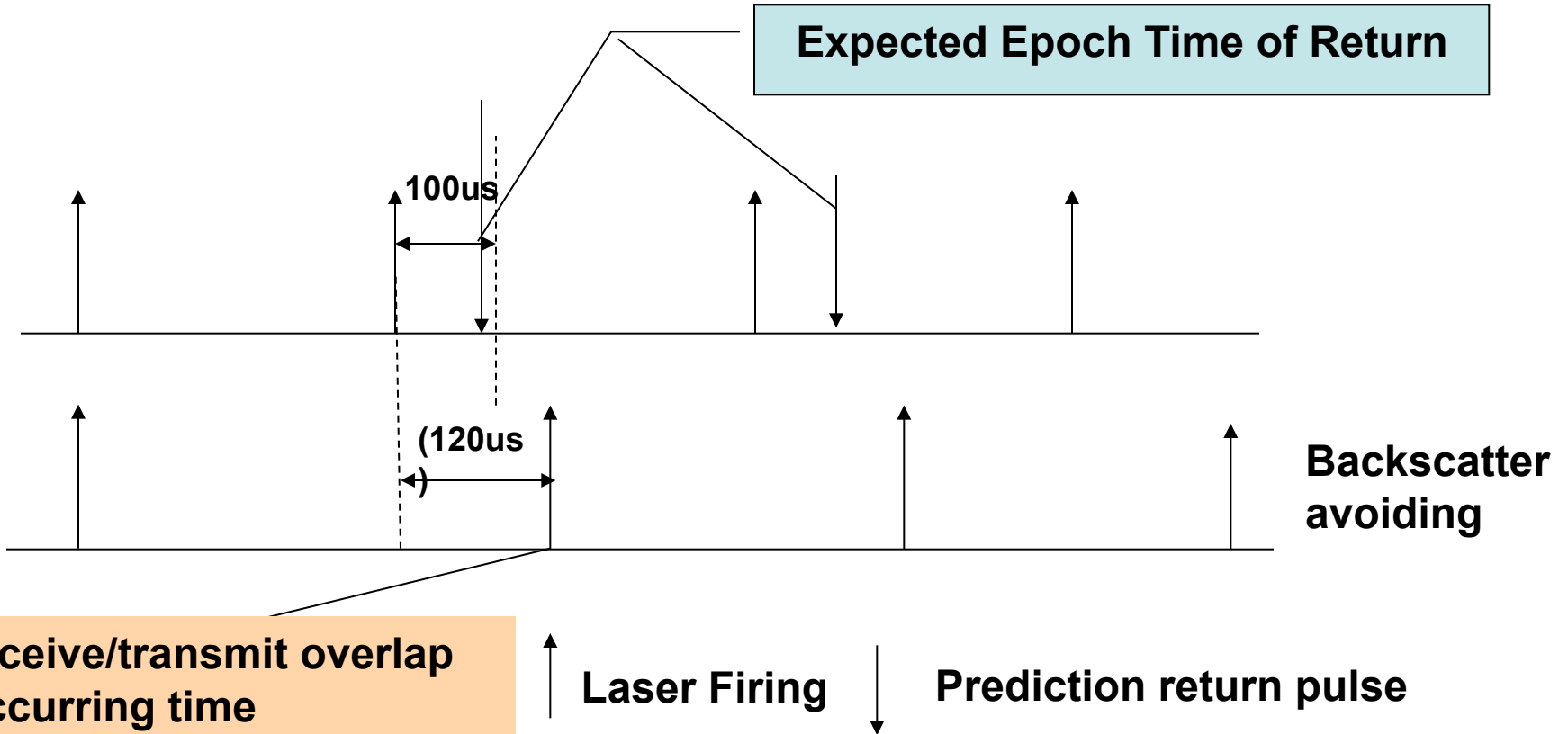

If < 100 us between Receive/ Transmit, Laser Firing will be shifted by (120 us).

kHz Control Software System

The kHz Control Software is designed and built by Shanghai Station. There are two computers used in the experiment in Windows OS:

- **One computer is used for communication with ET, recording start and stop events, and matching them, identifying, displaying residual (O-C), storing data, etc.**
- **Another computer is used for tracking and controlling, including laser firing, 1kHz range gating, receive and transmit overlap avoiding, etc.**

During the experiment, two computers communicate with each other via RS232.

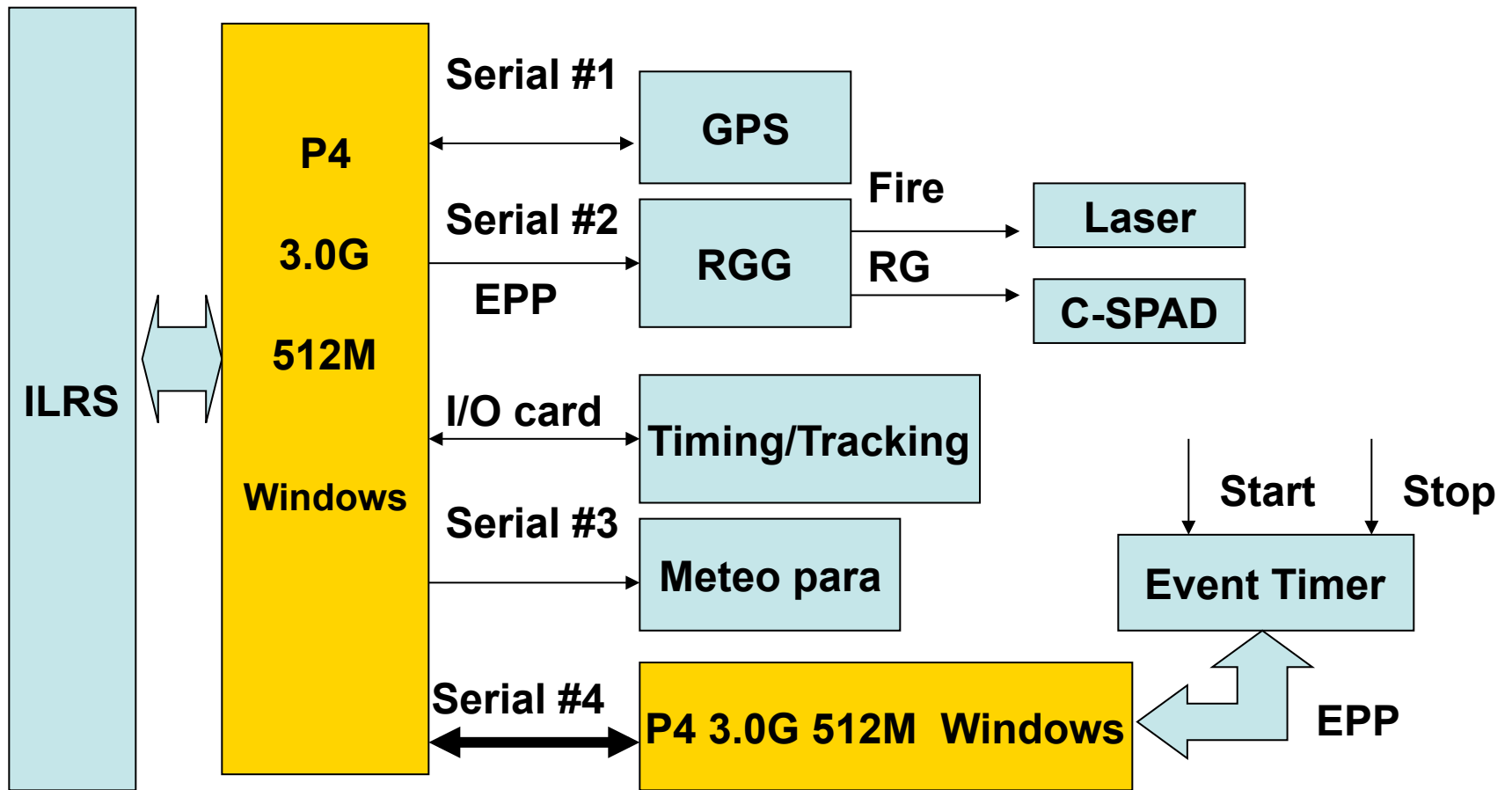

Block diagram of one kHz system

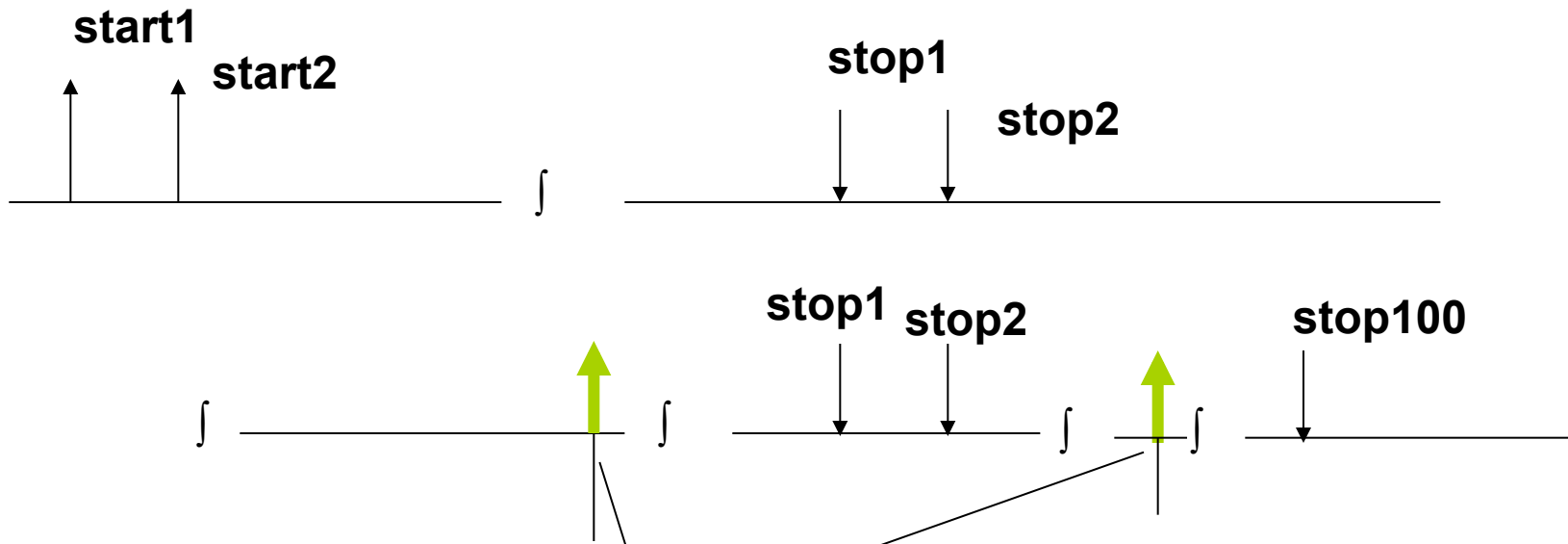

Put 100 expected epoch time of return into FIFO once a 100ms in advance to satisfy real-time control software

Time sequencing diagram of writing FIFO

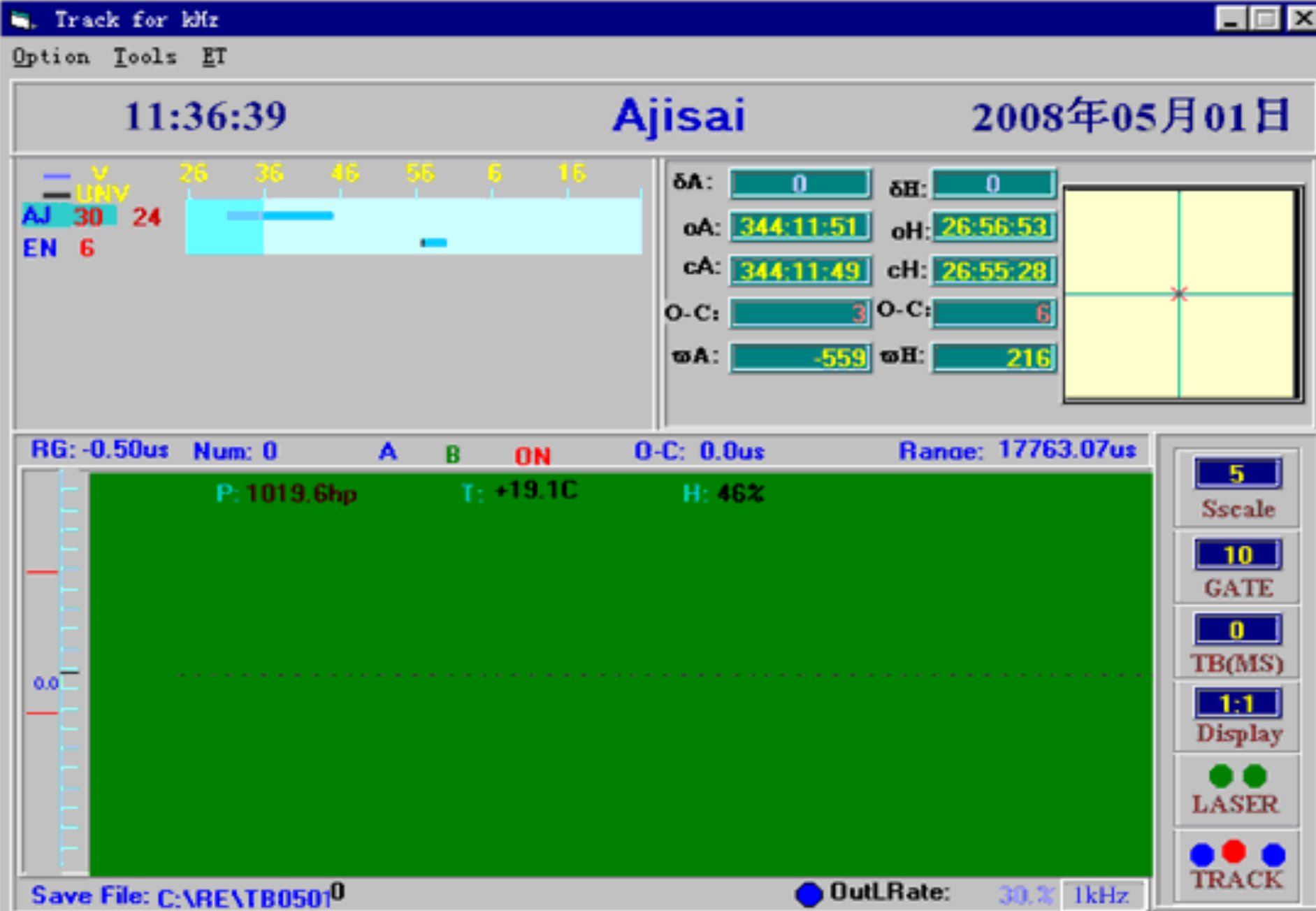

Real-time tracking interface for tracking, firing...

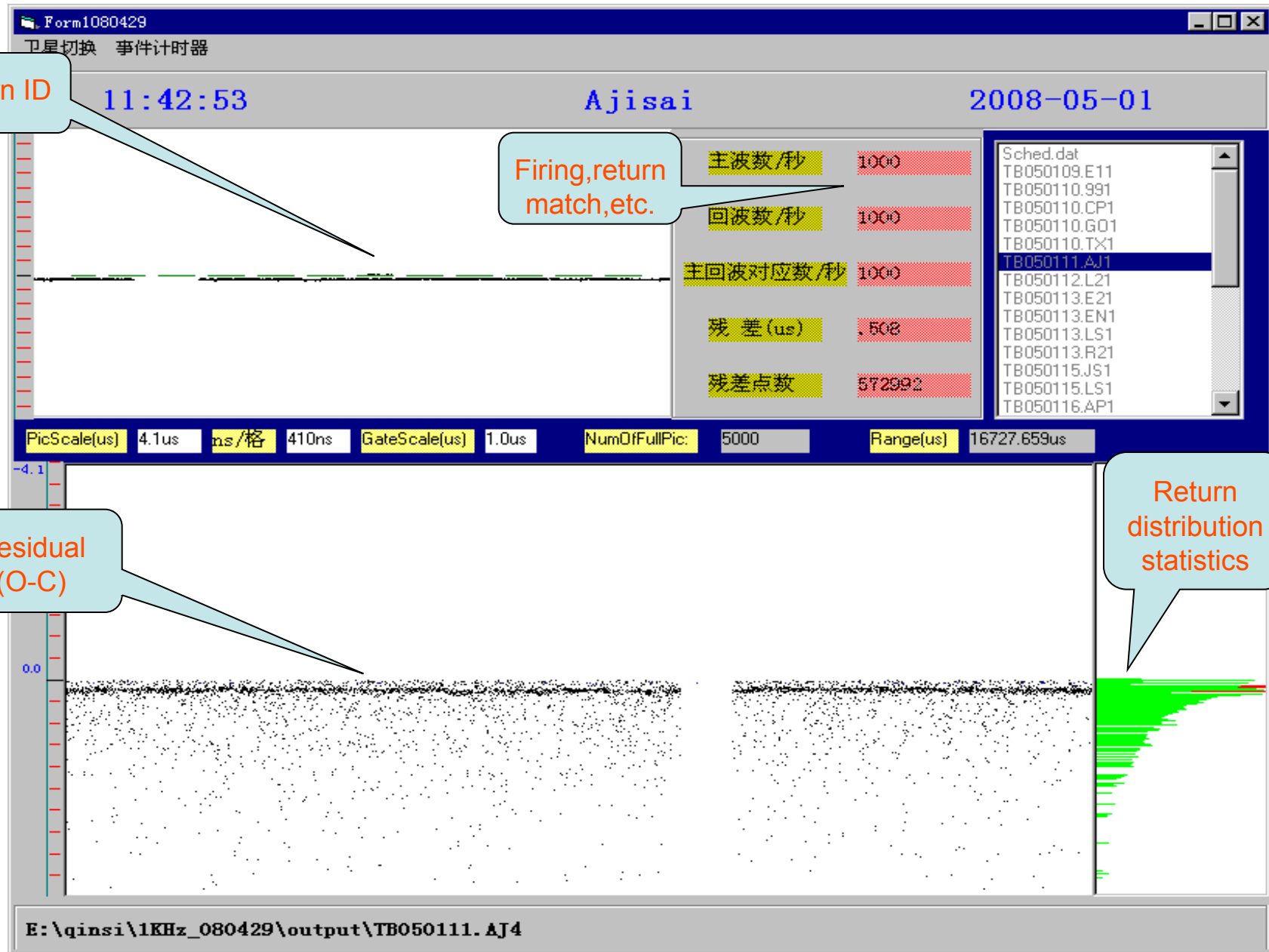

Another computer's real-time interface for recording start and stop events, displaying (O-C), etc.

Data Pre-Processing

- Displaying selected obs. data on screen
- Processing all data
- Advantage: fast, not influence result.

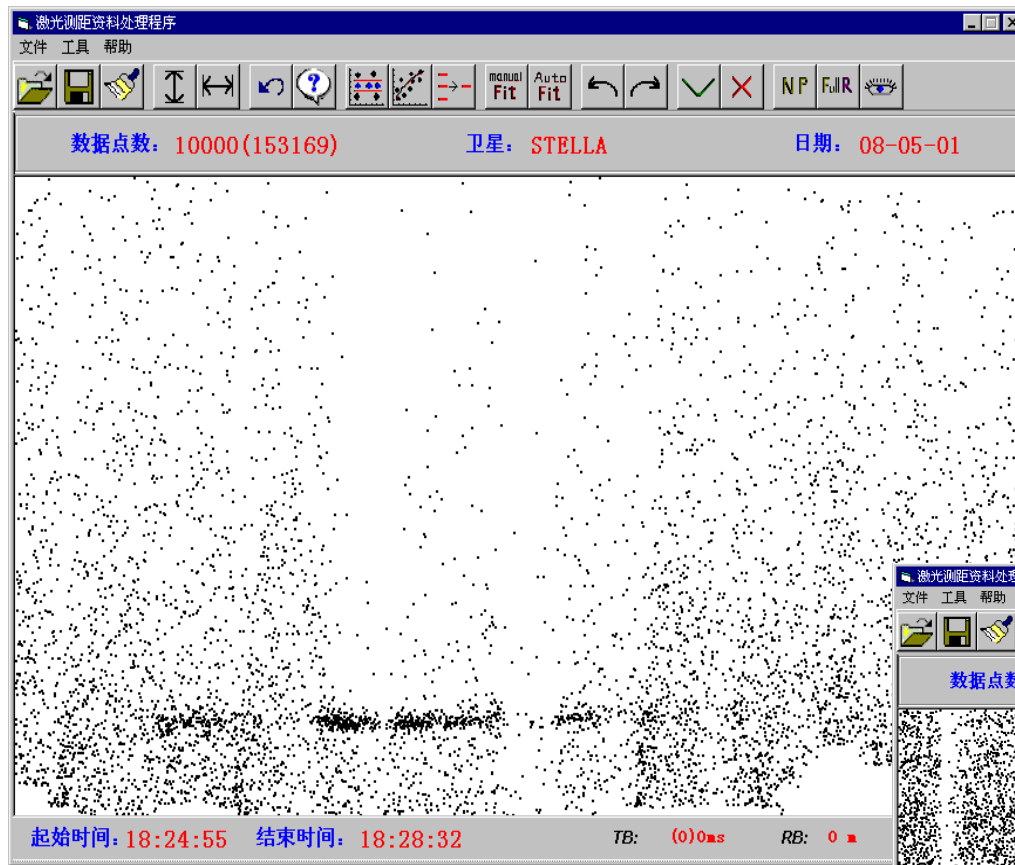

Selected obs. data screen

**Satellite: Stella
on May 1**

- 153k recorded
- 24k returns

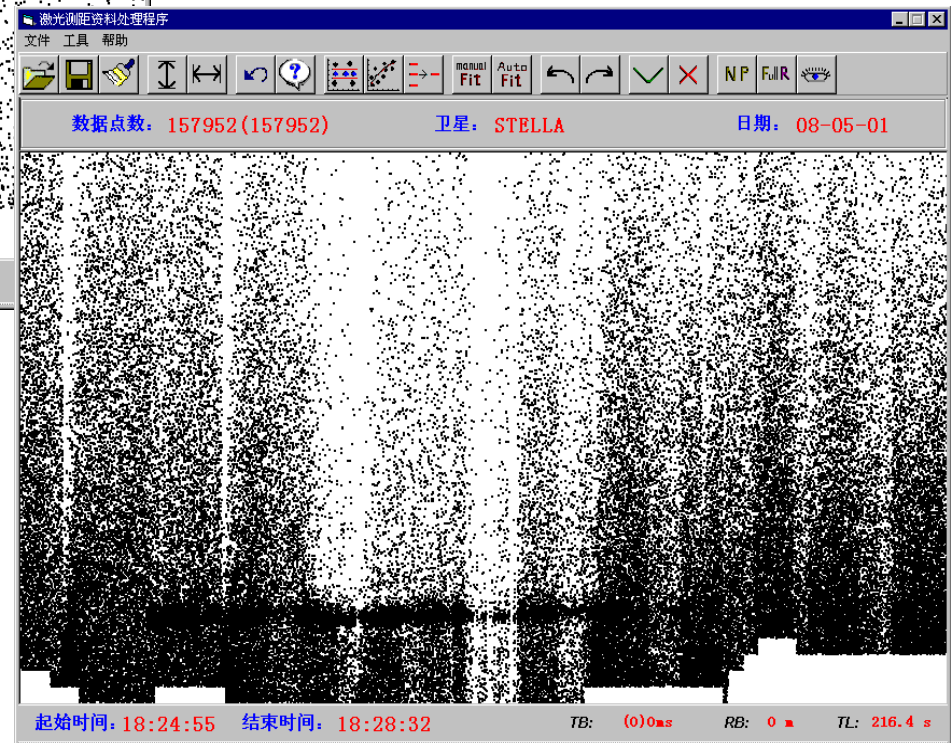

Full obs. data screen

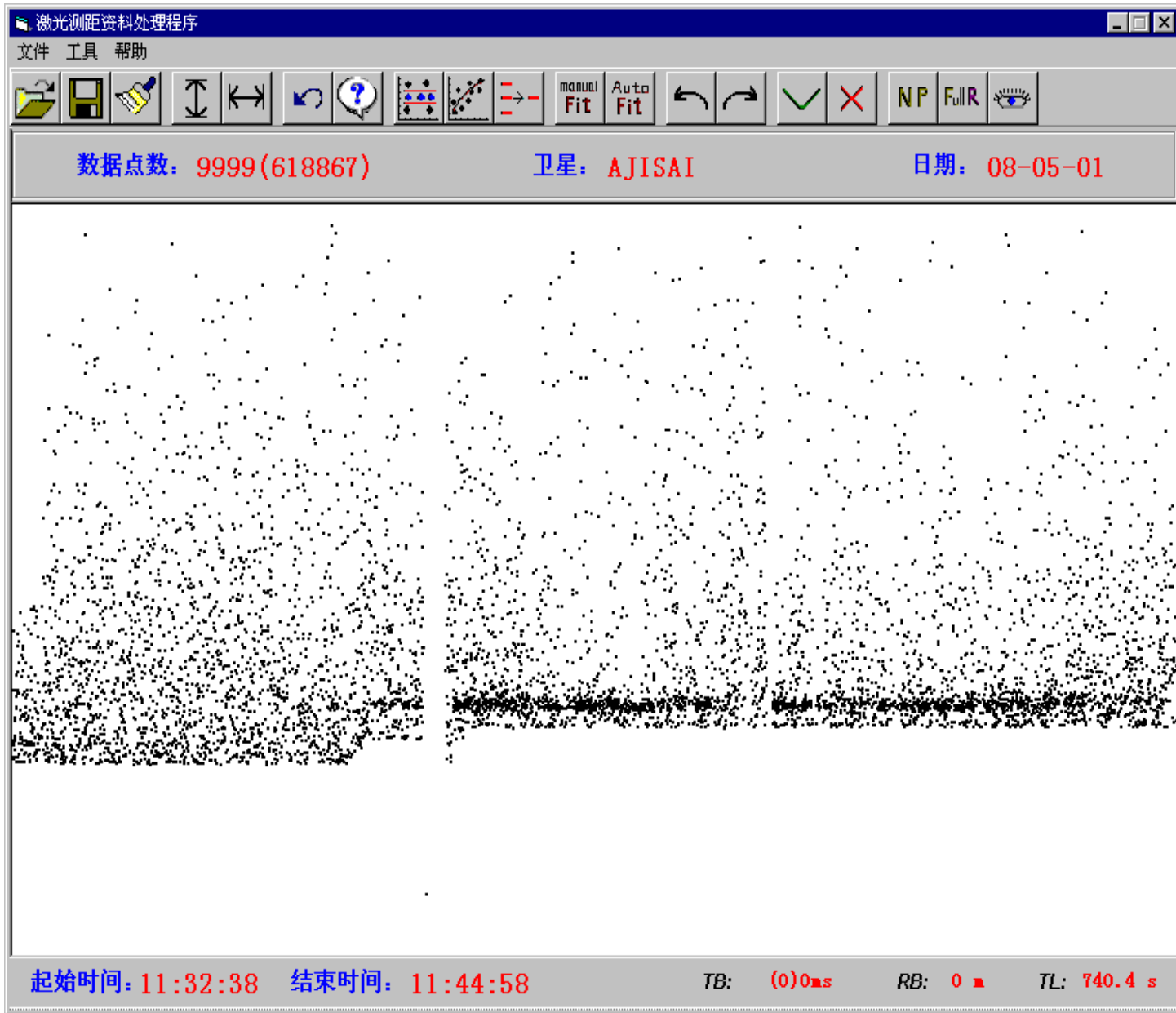

Satellite: Ajisai
on May 1

- 618k recorded
- 190k returns

Pre-Processing screen

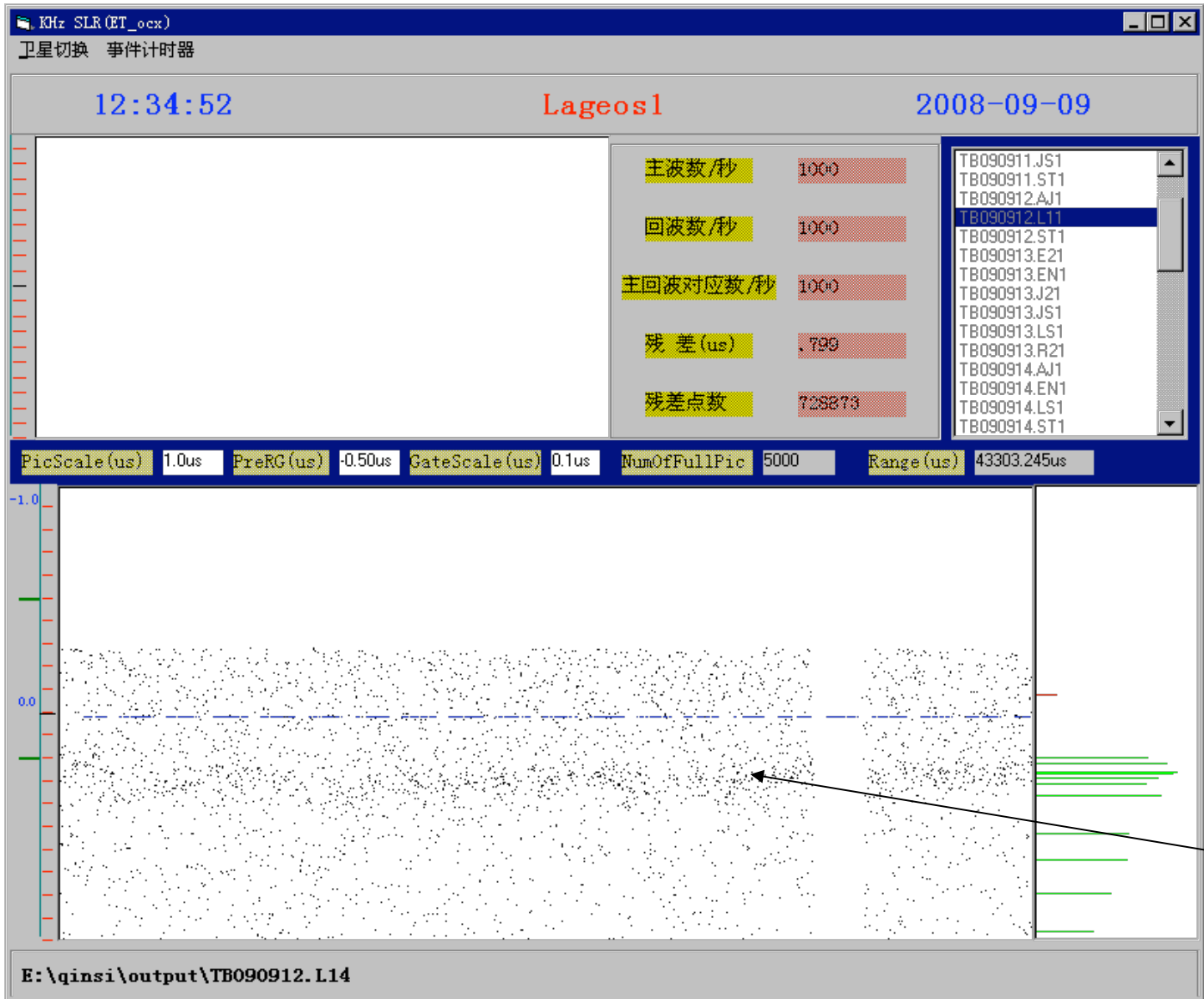

**Satellite:
Lageos-1
on Sep. 9**

– 900k recorded
– 60k returns

Valid data

Real-time interface for Lageos ranging

KHz SLR returns vs. Routine SLR at Shanghai station

Satellite	KHz SLR		Routine SLR
	Recorded	Returns	Returns
Ajisai	618k	190k	1500
Stella	153k	24k	500
BeaconC	81k	42k	800
Lageos1	900k	60k	1000

1 kHz SLR experiment's video (Ajisai, on May 1)

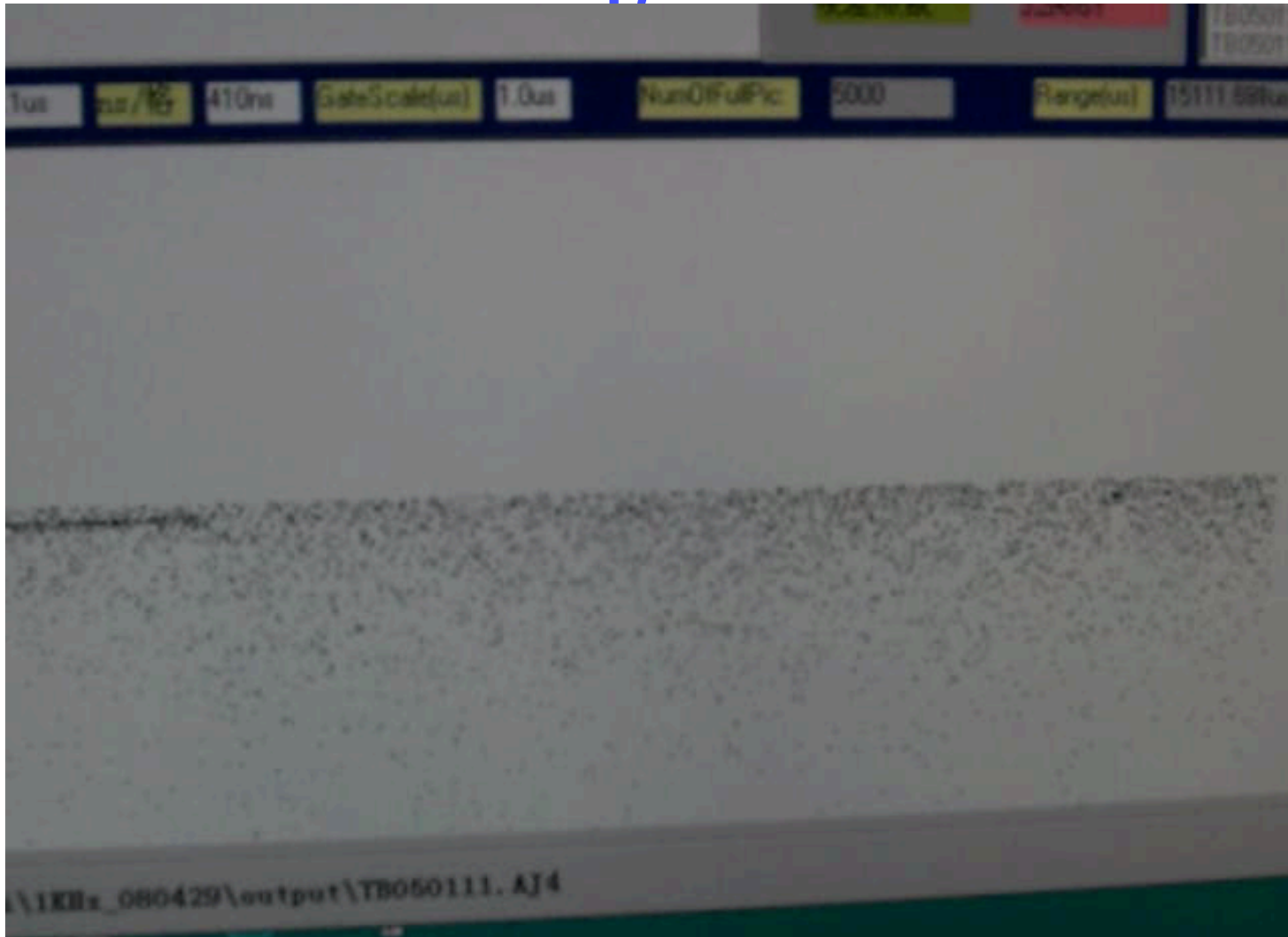

Summary

- We have successfully obtained returns from satellites (ajisai, stella, beaconC, ERS-2, Envisat, Lageos, etc.) by using a kHz laser with long pulse width. The experiment shows that 1 kHz control system works fine and promisefully.
- Plan to purchase a kHz laser with short pulse width next year, and to start routine kHz ranging with high precision.

Thank You !